

PROPOSED CONDITIONS

- 1 Proposed 2 no. town house subdivision on subject site with basement
Unit 1 - 2 storey townhouse with basement - 402.46m²
Unit 2 - 2 storey townhouse with basement - 383.54m²
- 2 Existing crossover to be trimmed back
- 3 Proposed new crossover for vehicle access to Unit 2
- 4 Ramp access to basement entry with permeable paving
- 5 Proposed canopy trees to front setback
- 6 Upper floor planters to soften street interface
- 7 Low shrub planting proposed adjacent to ramp
- 8 Proposed min. 4m high mature tree to internal courtyard to assist in natural screening
- 9 Proposed tree planting along rear boundary
- 10 Proposed creepers over open trellis to front boundary interface
- 11 External tiered setback to the rear to minimise visual bulk
- 12 Louver canopy over outdoor living area

DEVELOPMENT SUMMARY

Site Area:	785.00m ²
Ex. Site Coverage:	340.33m ² -43.35%
Ex. Permeability:	276.99m ² -35.28%
Ex. POS:	430.45m ²
Ex. SPOS:	277.63m ²
Ex. Garden Area:	429.87m ² -54.76%
UNIT 1	
Site Area:	402.42m ²
Prop. Site Coverage:	222.21m ²
Prop. Permeability:	98.433m ²
Prop. POS:	185.53m ²
Prop. SPOS:	100.17m ²
Prop. Garden Area:	146.27m ² -36.35%
UNIT 2	
Site Area:	383.59m ²
Prop. Site Coverage:	211.09m ²
Prop. Permeability:	85.59m ²
Prop. POS:	177.23m ²
Prop. SPOS:	92.46m ²
Prop. Garden Area:	128.98m ² -33.52%
TOTAL	
Prop. Site Coverage:	433.31m ² 55.20%
Prop. Permeability:	181.77m ² -23.16%
Prop. POS:	357.32m ²
Prop. SPOS:	192.63m ²
Prop. Garden Area:	275.25m ² -35.06%

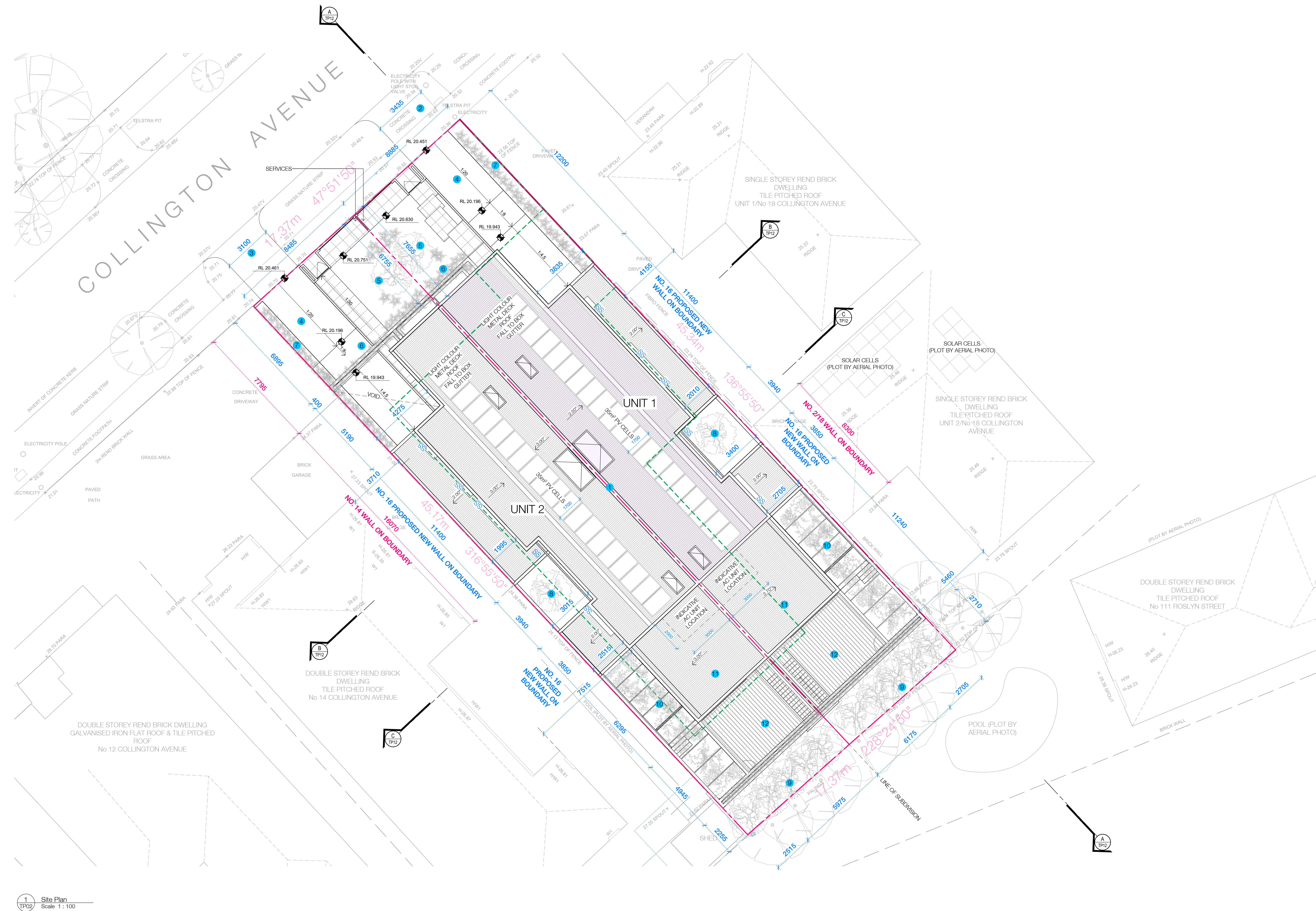

1 Site Plan
Scale 1:100

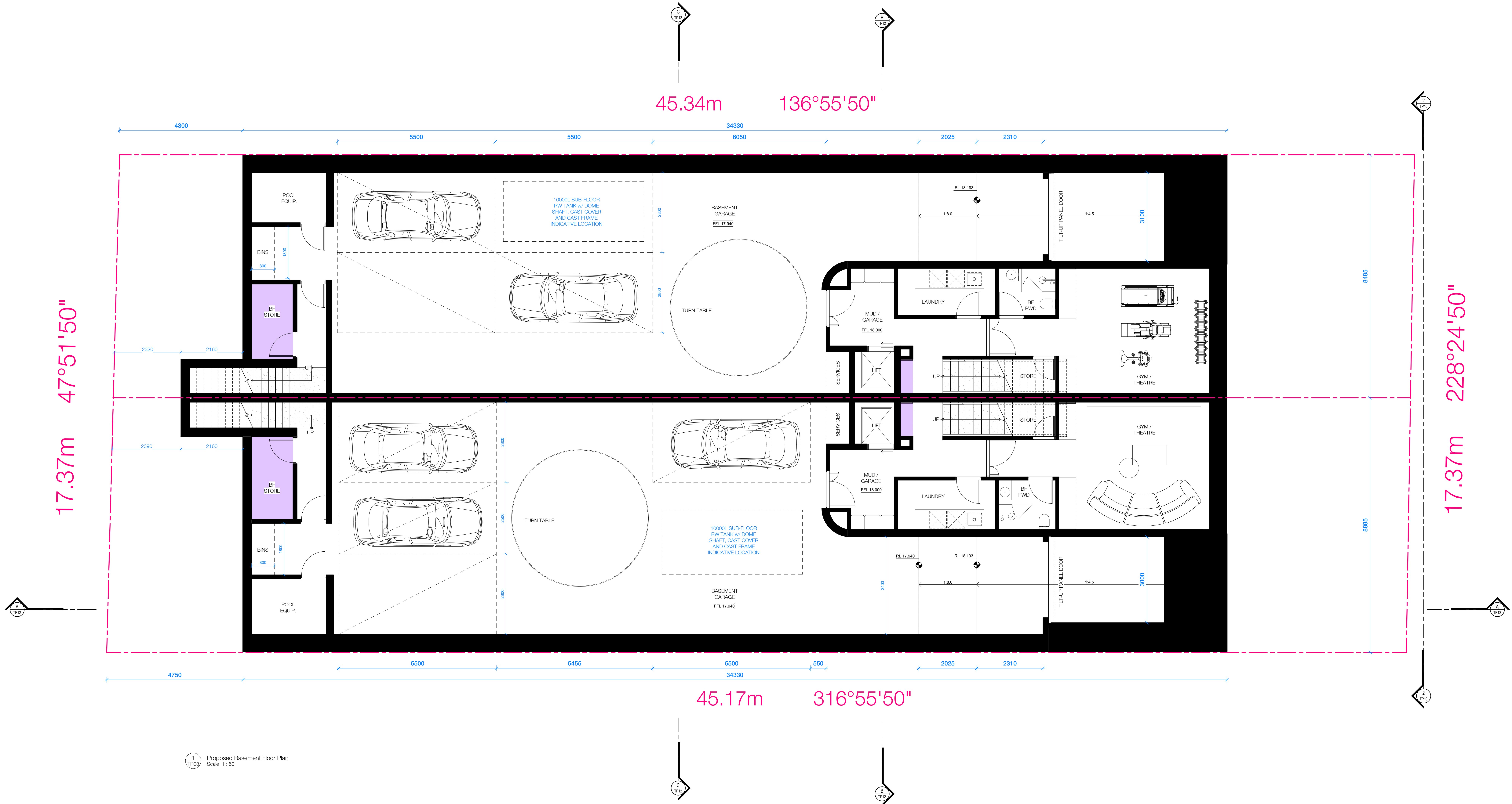

1 Proposed Basement Floor Plan
TP03
Scale: 1:50

Use figured dimensions in preference to scale. Verify dimensions at job before shop fabrication. Read drawing in conjunction with specification. In accepting and utilizing this document, the recipient agrees that NYC Architects retains all rights and copyright in this document and any derivation of the this document whether in electronic format or in 2D or 3D. The recipient agrees not to use this document for any purpose other than its intended use and waives all claims against NYC Architects resulting from unauthorized changes. The recipient agrees and accepts they have no right to use this document or any part of it for other projects without the prior written consent of NYC Architects. Under no circumstances shall the transfer of this document be deemed a transfer of any right title or interest in the copyright in the document.

REV.	DATE
a	20.03.26
b	27.03.26

DATE: 20.03.26
27.03.26

- SS SOLID, PERMANENT LOUVERED SUN SHADING DEVICE FIXED IN FRONT OF WINDOW WITH MAX. 25% OPENINGS (SEE TYPICAL LOUVER DETAIL)
- FULL-HEIGHT STORAGE - UNIT 1 - 83.78m²
UNIT 2 - 79.32m²

Project
16 Collington Avenue,
Brighton

Drawing
Proposed Basement
Plan

Scale: 1:50 (A0)
Date: 11.03.26
Drawn: NG
Architect: NYC

Drawing No:
F2509
TP03 b

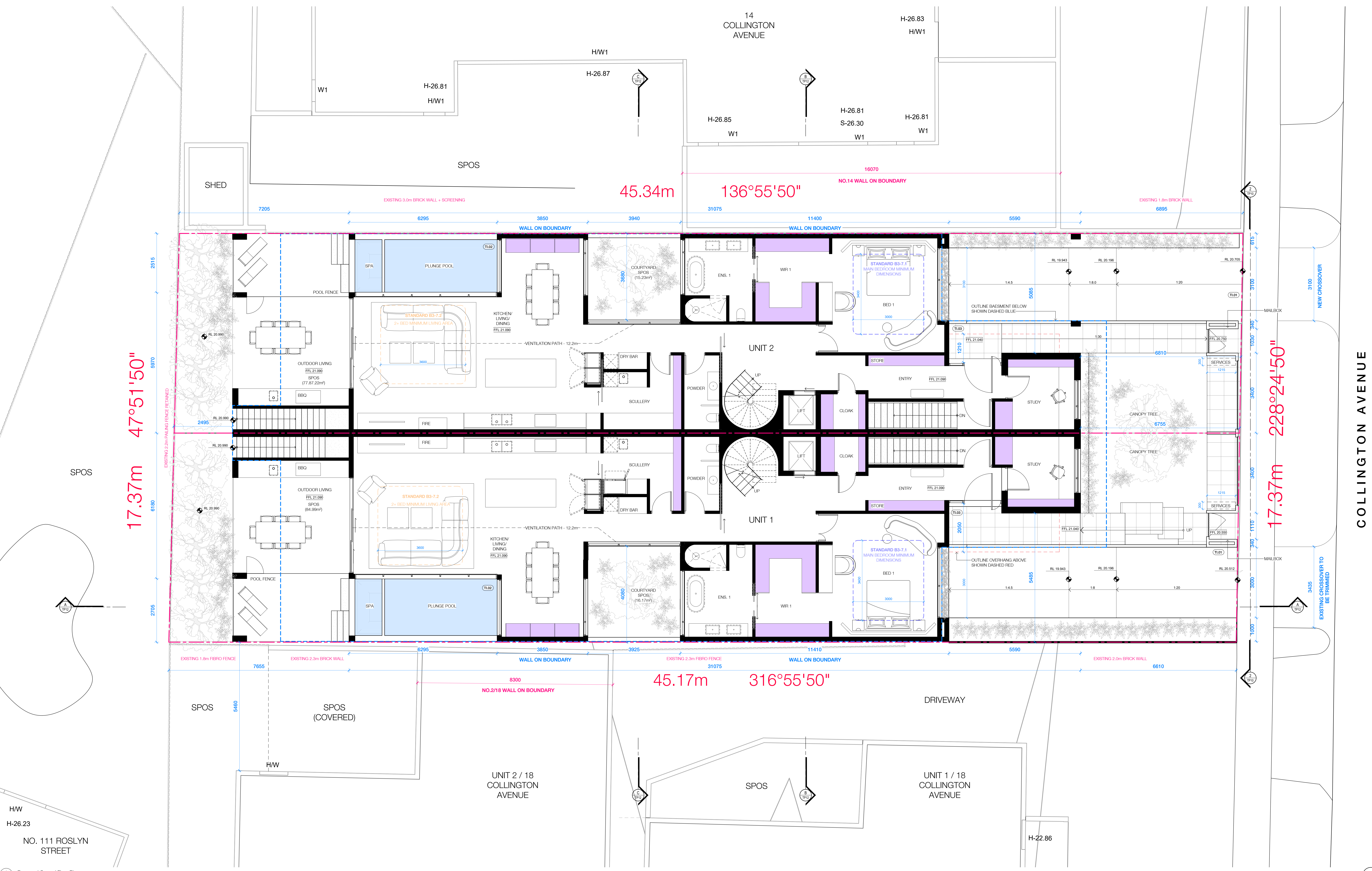

H/W
H-26.23
NO. 111 ROSLYN STREET

1 Proposed Ground Floor Plan
Scale 1:150



41 Tanner Street
Richmond Victoria, Australia 3121
Telephone +61 411 032 184
Email studio@fycarchitects.com
Instagram fyc.a
Web www.fycarchitects.com

Use figured dimensions in preference to scale. Verify dimensions at job before shop fabrication. Read drawing in conjunction with specification. In accepting and utilizing this document, the recipient agrees that fyc architects retains all rights and copyright in this document and any derivation of the this document whether in electronic format or in 2D or 3D. The recipient agrees not to use this document for any purpose other than its intended use and waives all claims against fyc architects resulting from unauthorized changes. The recipient agrees and accepts they have no right to use this document or any part of it for other projects without the prior written consent of fyc architects. Under no circumstances shall the transfer of this document be deemed a transfer of any right title or interest in the copyright in the document.
© fyc architects 2023

REV: # Scheme revised to meet Garden Area Compliance
b Amended Spa & Pool

DATE: 20.03.26
27.03.26

SS SOLID, PERMANENT LOUVRED SUN SHADING DEVICE
FIXED IN FRONT OF WINDOW WITH MAX. 25% OPENINGS
(SEE TYPICAL LOUVRE DETAIL)
FULL-HEIGHT STORAGE -
UNIT 1 - 83.78m²
UNIT 2 - 79.32m²

Project
16 Collington Avenue,
Brighton

Drawing
Proposed Ground Floor
Plan

Scale: 1:50 (B/A)
Date: 11.03.26
Drawn: NG
Architect: fyc

Drawing No:
F2509

TP04 b

COLLINGTON AVENUE

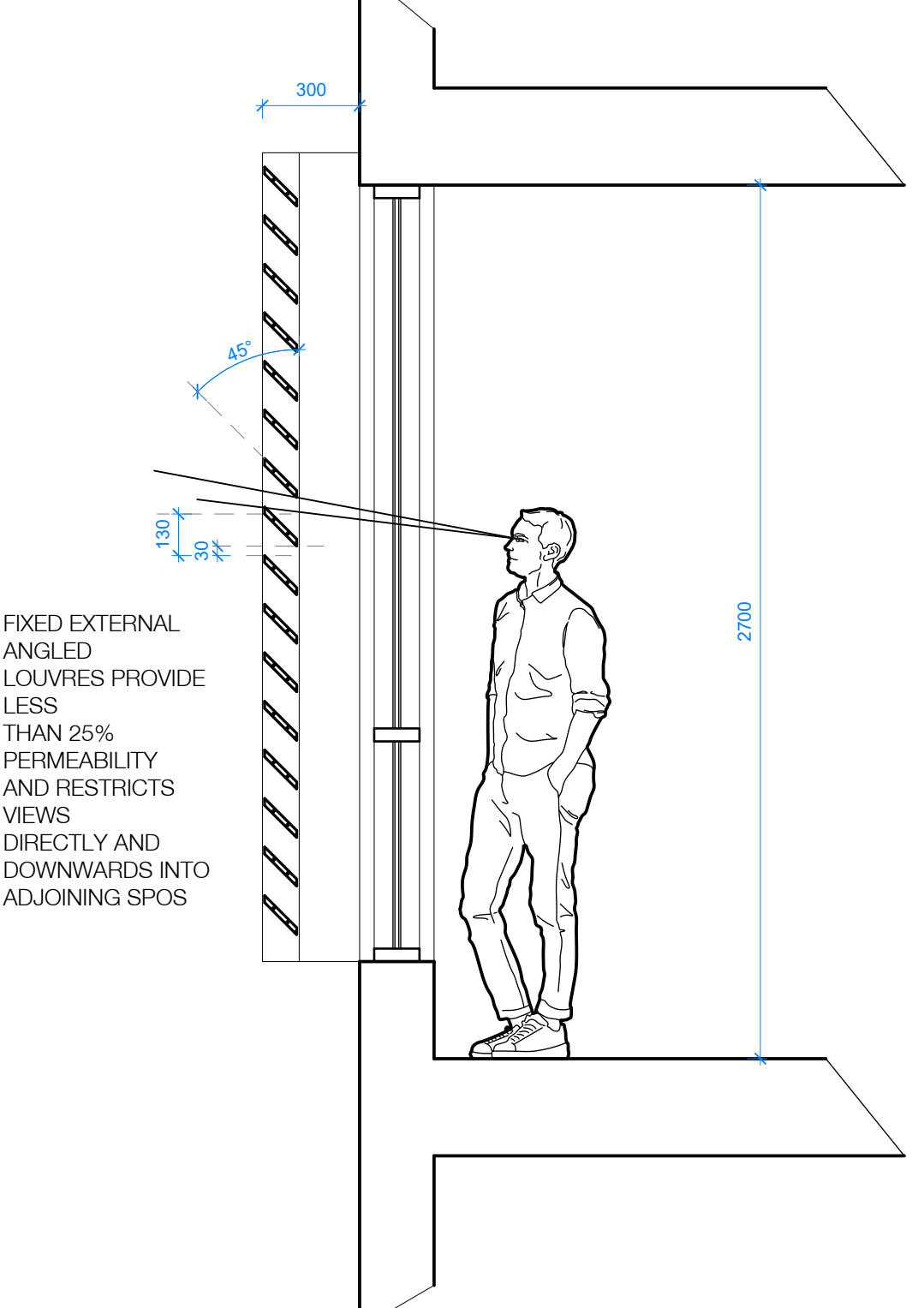

TYPICAL LOUVRE DETAIL
Scale 1:20

17.37m 47°51'50"

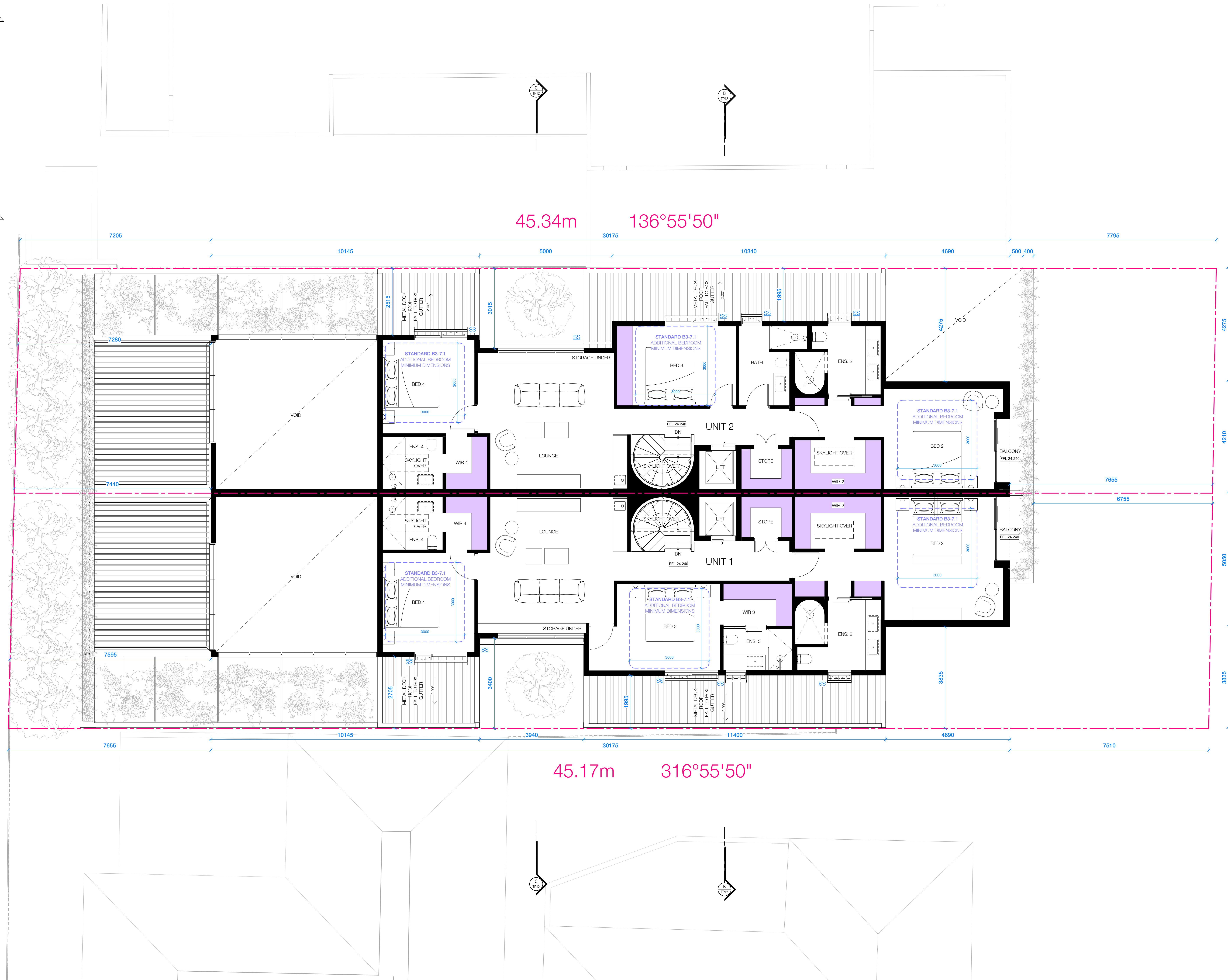
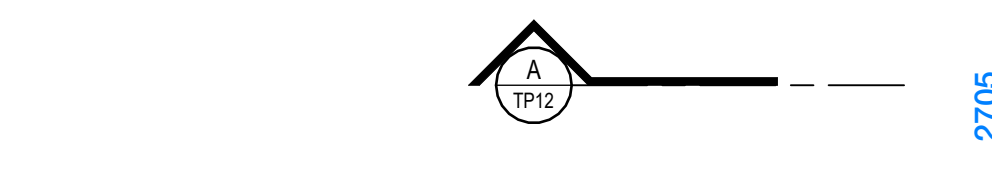

17.37m 228°24'50"



1 Proposed First Floor Plan
Scale 1:50

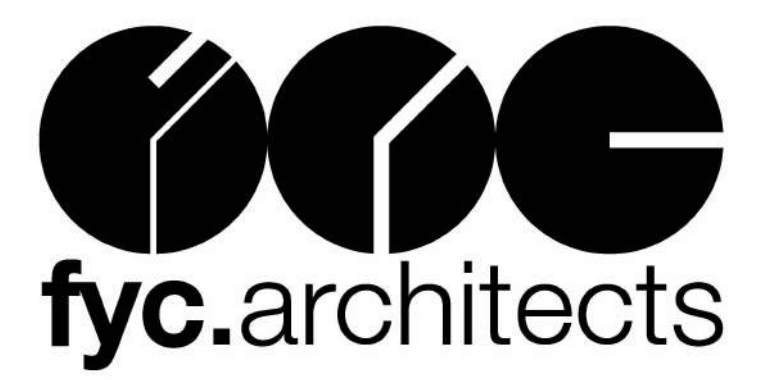

41 Tanner Street
Richmond Victoria, Australia 3121
Telephone +61 411 032 1834
Email studio@fycarchitects.com
Instagram fyc.a
Web www.fycarchitects.com

Use figured dimensions in preference to scale. Verify dimensions at job before shop fabrication. Read drawing in conjunction with specification. In accepting and utilizing this document, the recipient agrees that fyc architects retains all rights and copyright in this document and any derivation of the this document whether in electronic format or in 2D or 3D. The recipient agrees not to use this document for any purpose other than its intended use and waives all claims against fyc architects resulting from unauthorized changes. The recipient agrees and accepts they have no right to use this document or any part of it for other projects without the prior written consent of fyc architects. Under no circumstances shall the transfer of this document be deemed a transfer of any right title or interest in the copyright in the document.
© fyc architects 2023

REV.	DATE
a	20.03.26
b	27.03.26

Scheme revised to meet Garden Area Compliance
Amended Spa & Pool

- SS SOLID, PERMANENT LOUVRED SUN SHADING DEVICE FIXED IN FRONT OF WINDOW WITH MAX. 25% OPENINGS (SEE TYPICAL LOUVRE DETAIL)
- Full-height storage - UNIT 1 - 83.78m²
UNIT 2 - 79.32m²

Project
16 Collington Avenue,
Brighton

Drawing
Proposed First Floor
Plan

Scale 1:50@A0
Date 11.03.26
Drawn NG
Architect FYC

Drawing No.
F2509
TP05 b

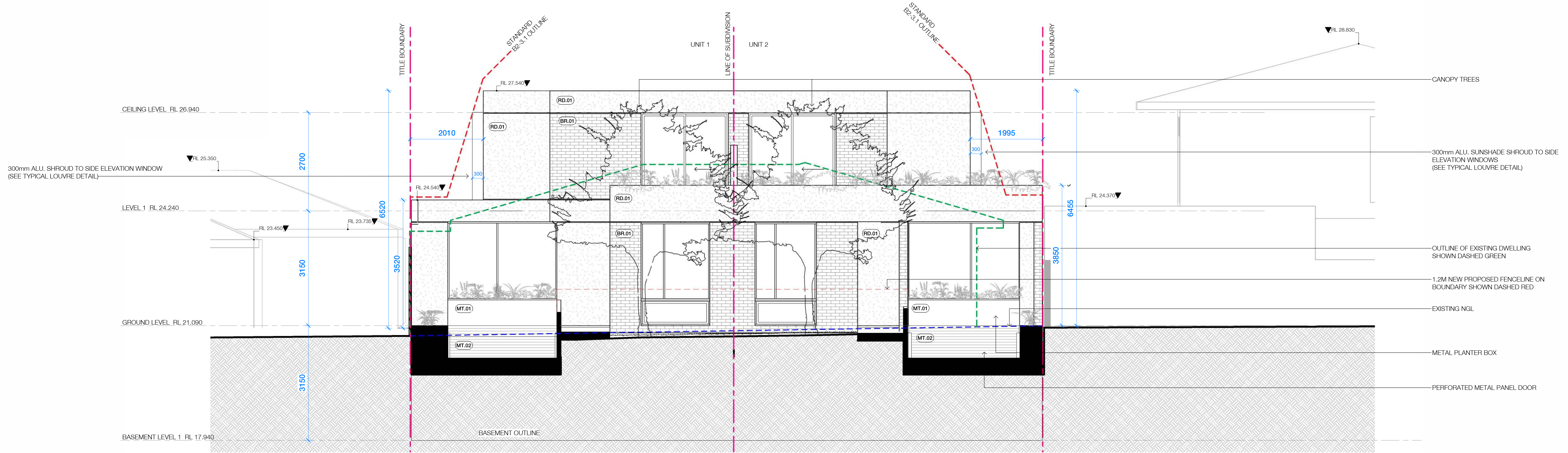

1 NORTHWEST ELEVATION - PROPOSED
Scale 1:50

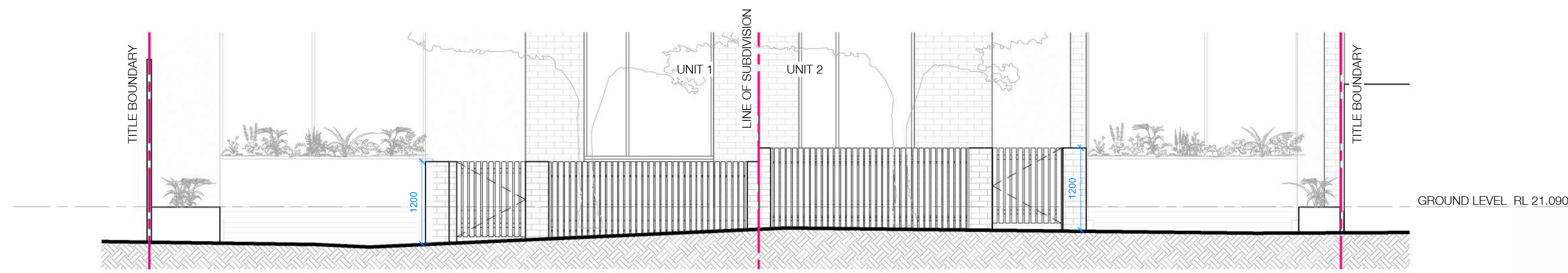

2 FRONT FENCE ELEVATION
Scale 1:50

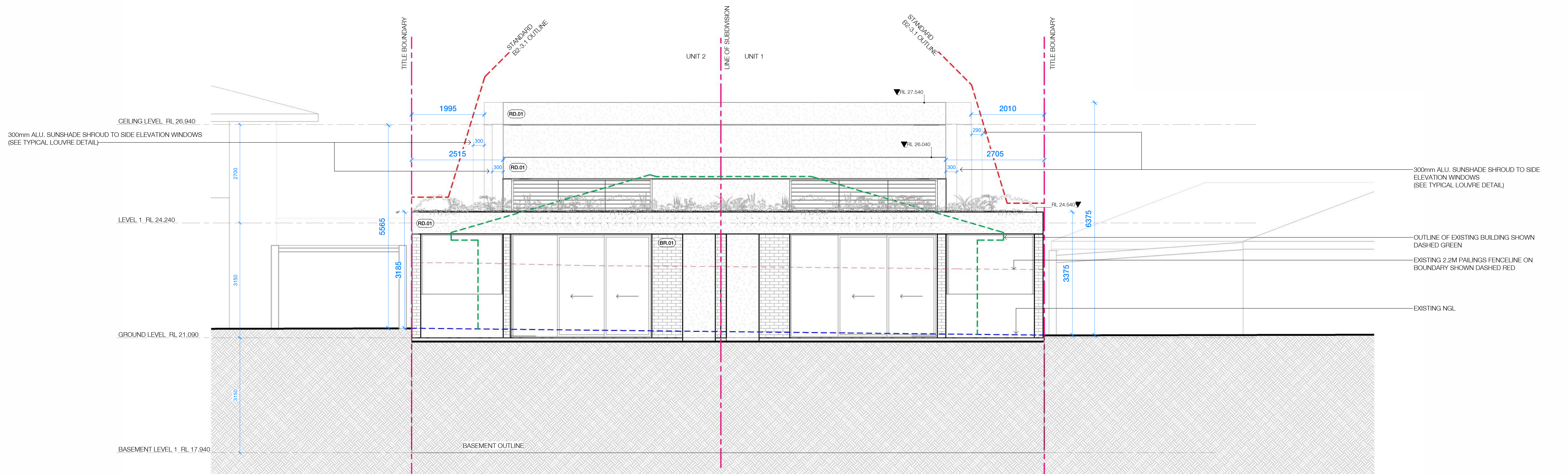

3 SOUTHEAST ELEVATION - PROPOSED
Scale 1:50



TL01 TACTILE PAVING
COLOUR: NATURAL STONE
OR SIMILAR



TL02 GREEN POOL TILE 100x100mm
WHITE MORTAR



TL03 NATURAL STONE PAVERS
MORTAR TO MATCH



MT.01 METAL SHROUD, LOUVRES, &
WINDOW FRAMES
COLOUR: CHAMPAGNE KINETIC
OR SIMILAR

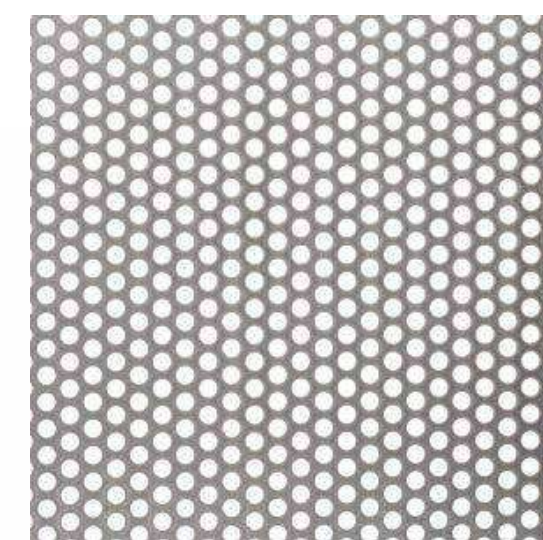

MT.02 TILT-UP PERFORATED METAL DOOR
COLOUR: WHITE



MT.03 METAL DECK ROOF
COLOUR: SNOWFIELD OR SIMILAR
OR SIMILAR



RD.01 TEXTURED RENDER FINISH



BR.01 BRICK WALL FINISH
COLOUR: SNOWFIELD OR SIMILAR
MORTAR TO MATCH

MATERIAL SCHEDULE
Not to Scale

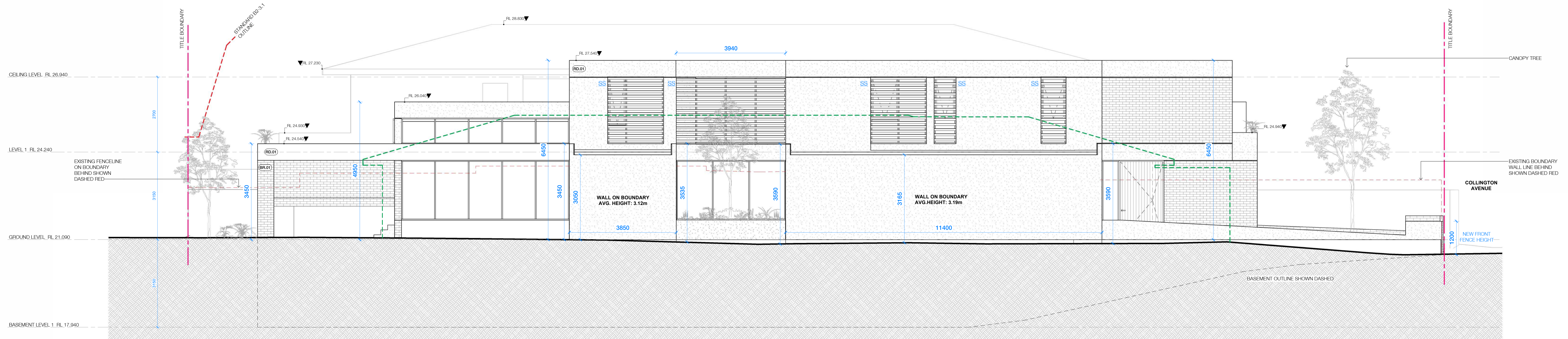

1 NORTHEAST ELEVATION - PROPOSED
Scale 1:50

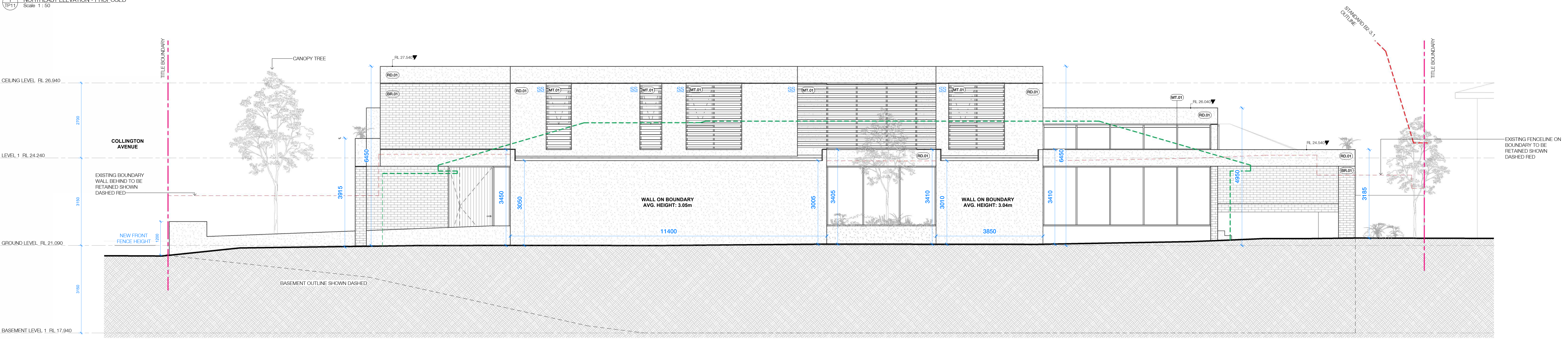

2 SOUTHWEST ELEVATION - PROPOSED
Scale 1:50



T1.01 TACTILE PAVING
COLOUR: NATURAL STONE OR SIMILAR

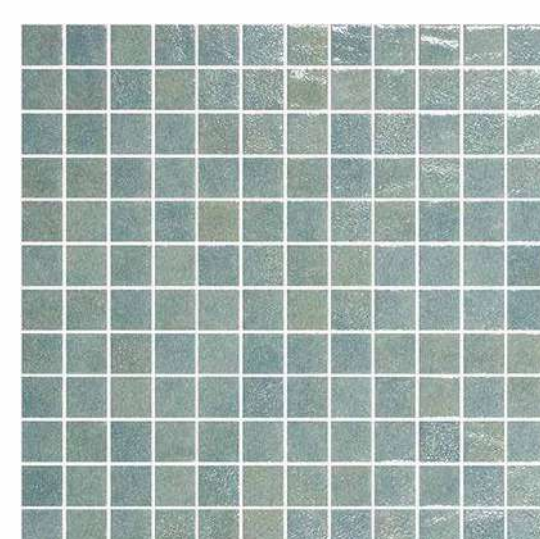

T1.02 GREEN POOL TILE 100x100mm
WHITE MORTAR



T1.03 NATURAL STONE PAVERS
MORTAR TO MATCH



MT.01 METAL SHROUD, LOUVRES, & WINDOW FRAMES
COLOUR: CHAMPAGNE KINETIC OR SIMILAR

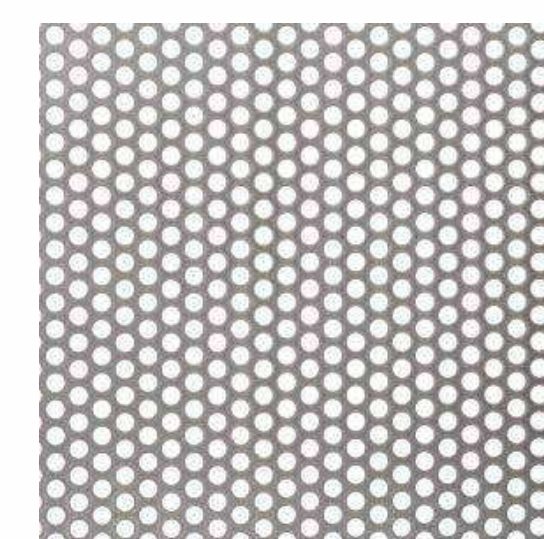

MT.02 TILT-UP PERFORATED METAL DOOR
COLOUR: WHITE



MT.03 METAL DECK ROOF
COLORBOND DOVER WHITE OR SIMILAR



RD.01 TEXTURED RENDER FINISH



BR.01 BRICK WALL FINISH
COLOUR: SNOWFIELD OR SIMILAR
MORTAR TO MATCH

MATERIAL SCHEDULE
Not to Scale

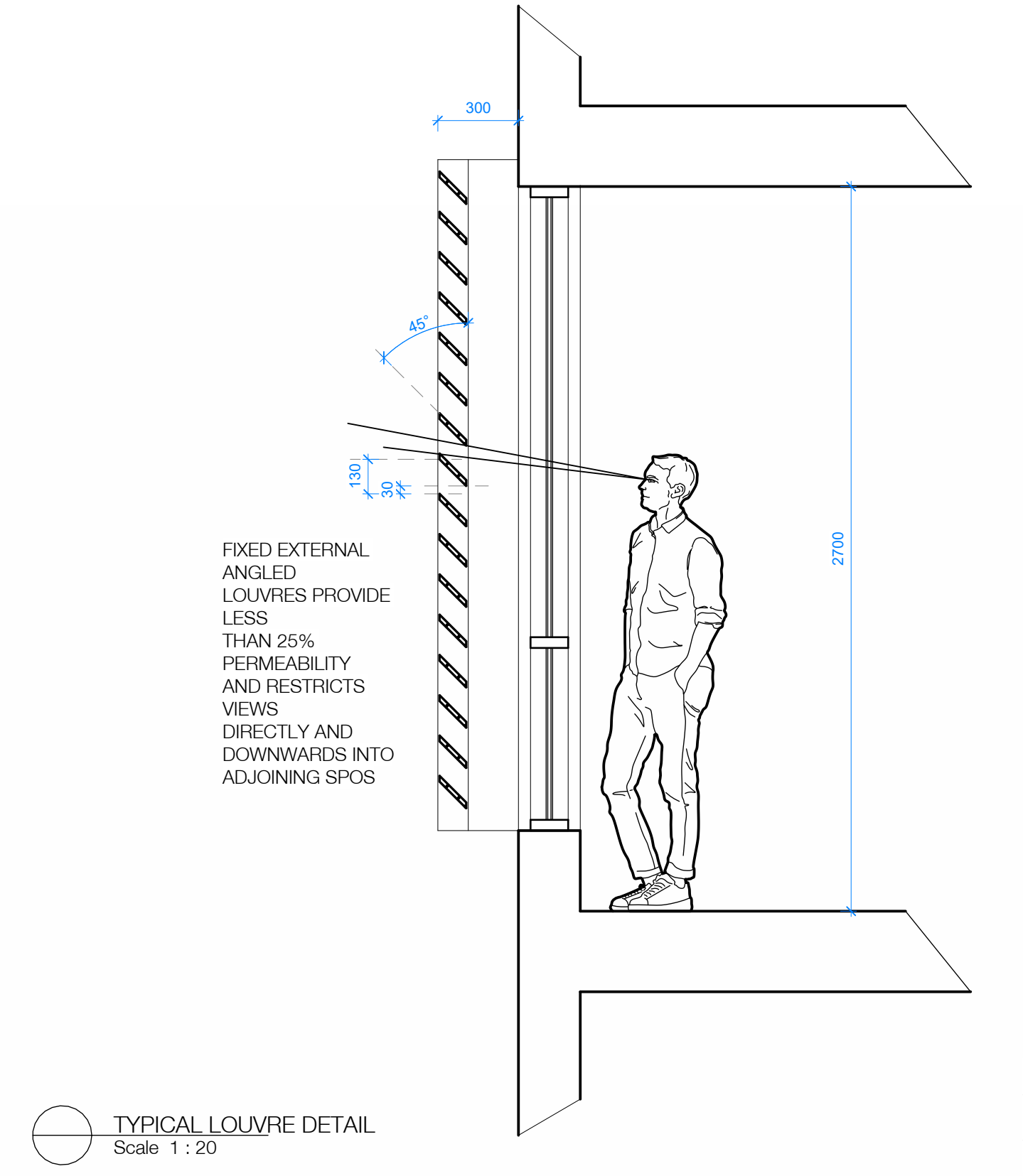

TYPICAL LOUVRE DETAIL
Scale 1:20

NOTE:
- EXISTING NGL AT ELEVATION LINE SHOWN
DASHED BLUE
- EXISTING BUILDING OUTLINE SHOWN
DASHED GREEN

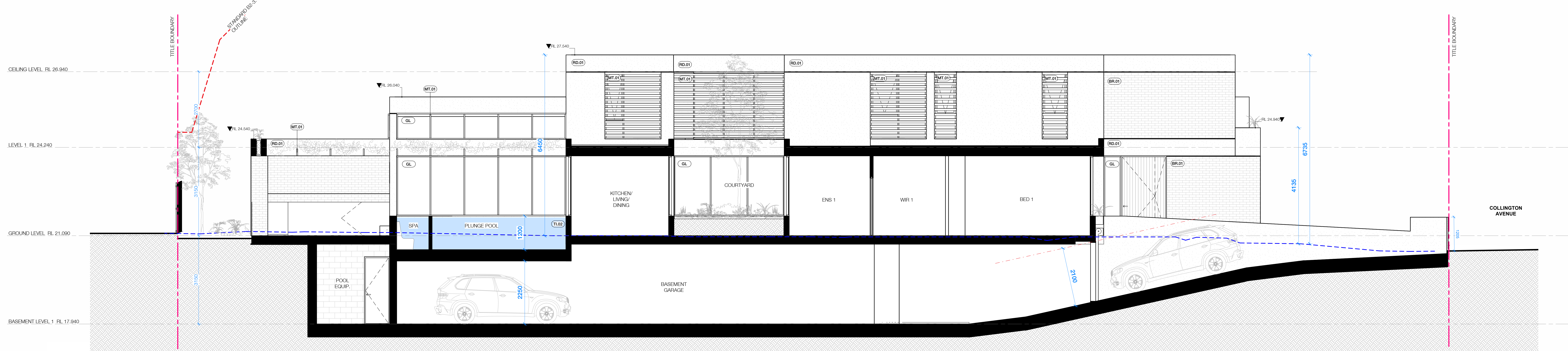

Section A
TP12
Scale 1:50

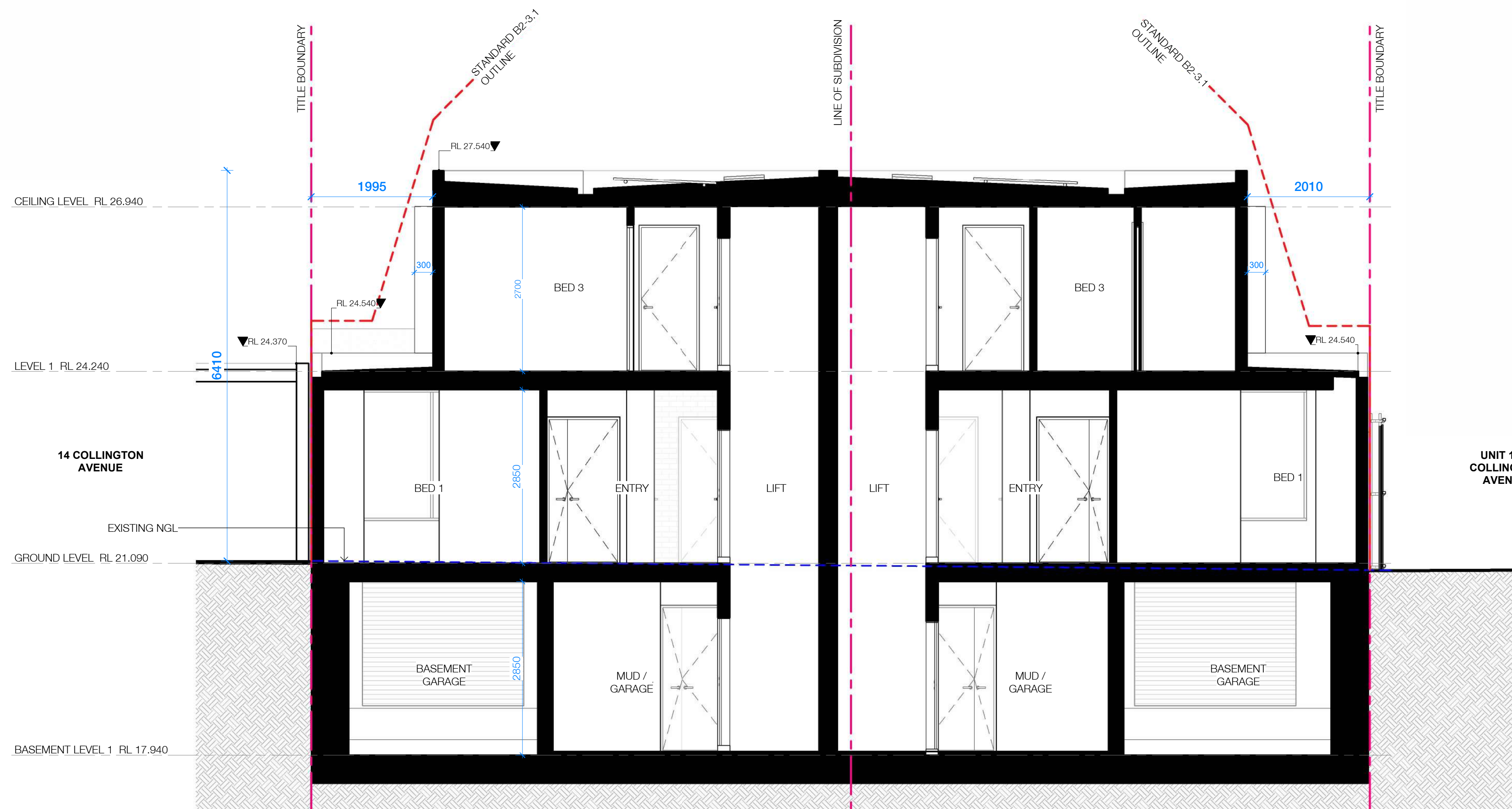

Section B
TP12
Scale 1:50

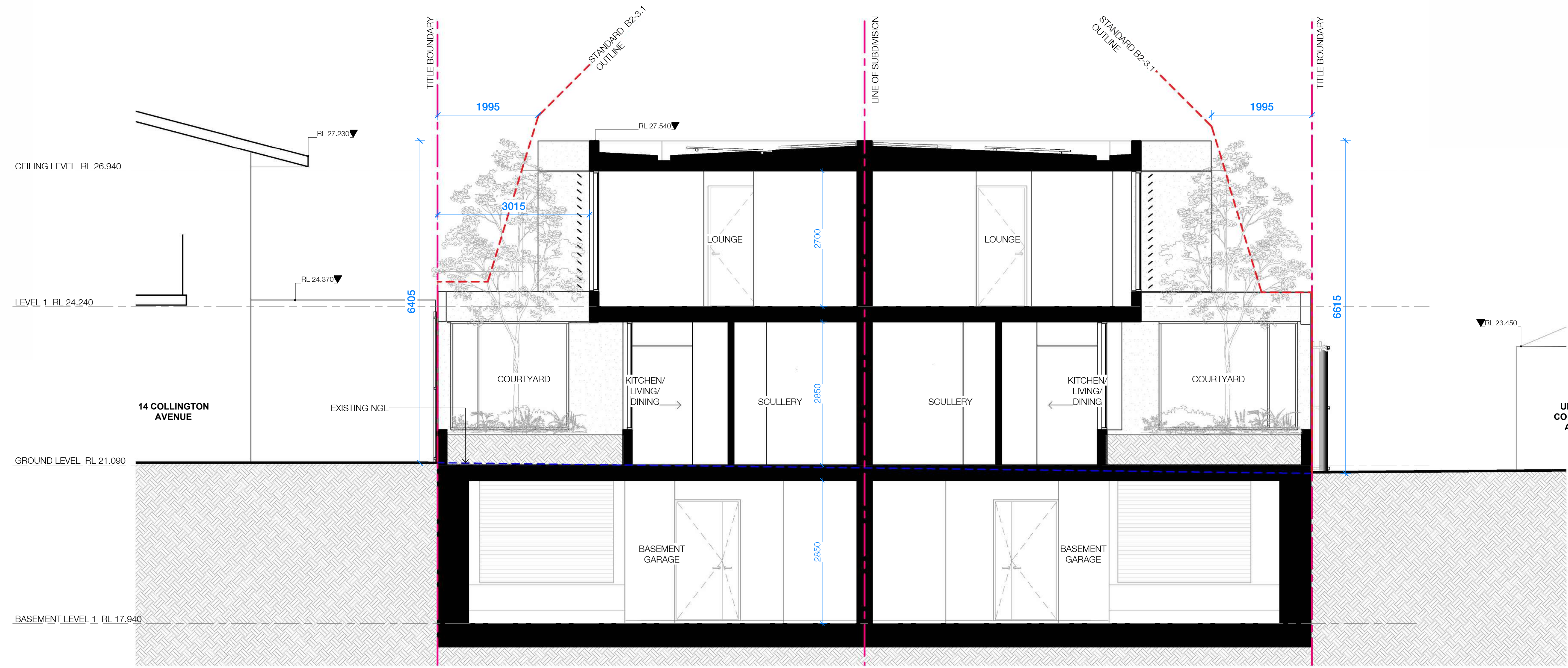

Section C
TP12
Scale 1:50



T1.01 TACTILE PAVING
COLOUR: NATURAL STONE
OR SIMILAR



T1.02 GREEN POOL TILE 100x100mm
WHITE MORTAR



T1.03 NATURAL STONE PAVERS
MORTAR TO MATCH



MT.01 METAL SHROUD, LOUVRES, &
WINDOW FRAMES
COLOUR: CHAMPAGNE KINETIC
OR SIMILAR

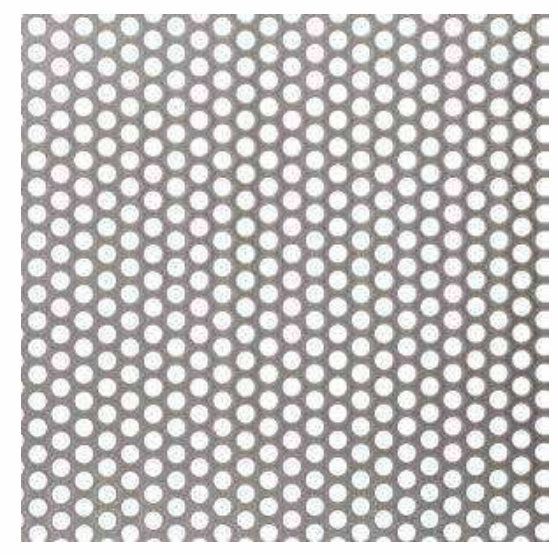

MT.02 TILT-UP PERFORATED METAL DOOR
COLOUR: WHITE



MT.03 METAL DECK ROOF
COLOUR: SNOWFIELD OR SIMILAR
MORTAR TO MATCH



RD.01 TEXTURED RENDER FINISH



BR.01 BRICK WALL FINISH
COLOUR: SNOWFIELD OR SIMILAR
MORTAR TO MATCH

MATERIAL SCHEDULE
Not to Scale

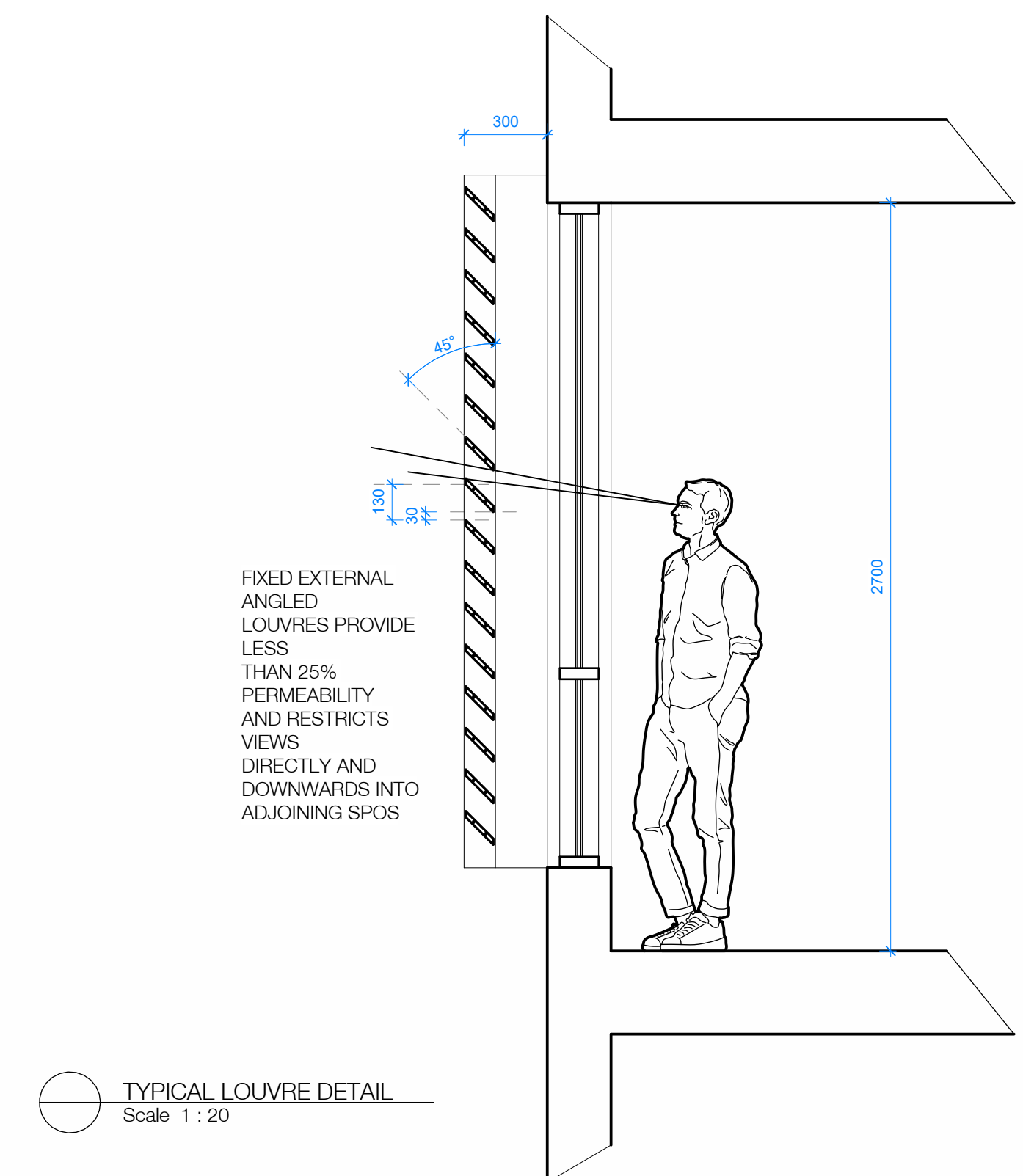

TYPICAL LOUVRE DETAIL
Scale 1:20

NOTE:
- EXISTING NGL AT SECTION CUT
LINE SHOWN DASHED BLUE

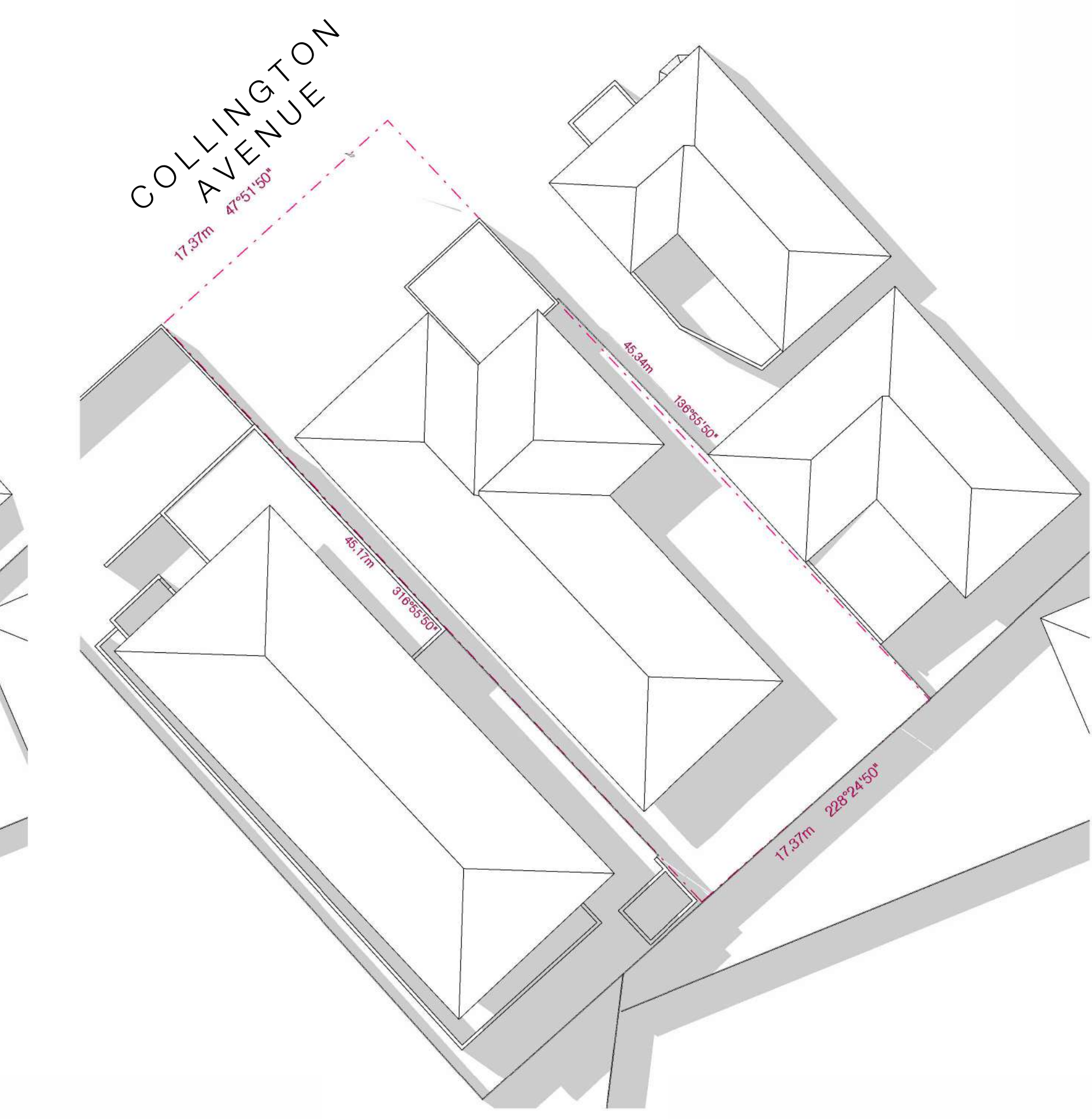
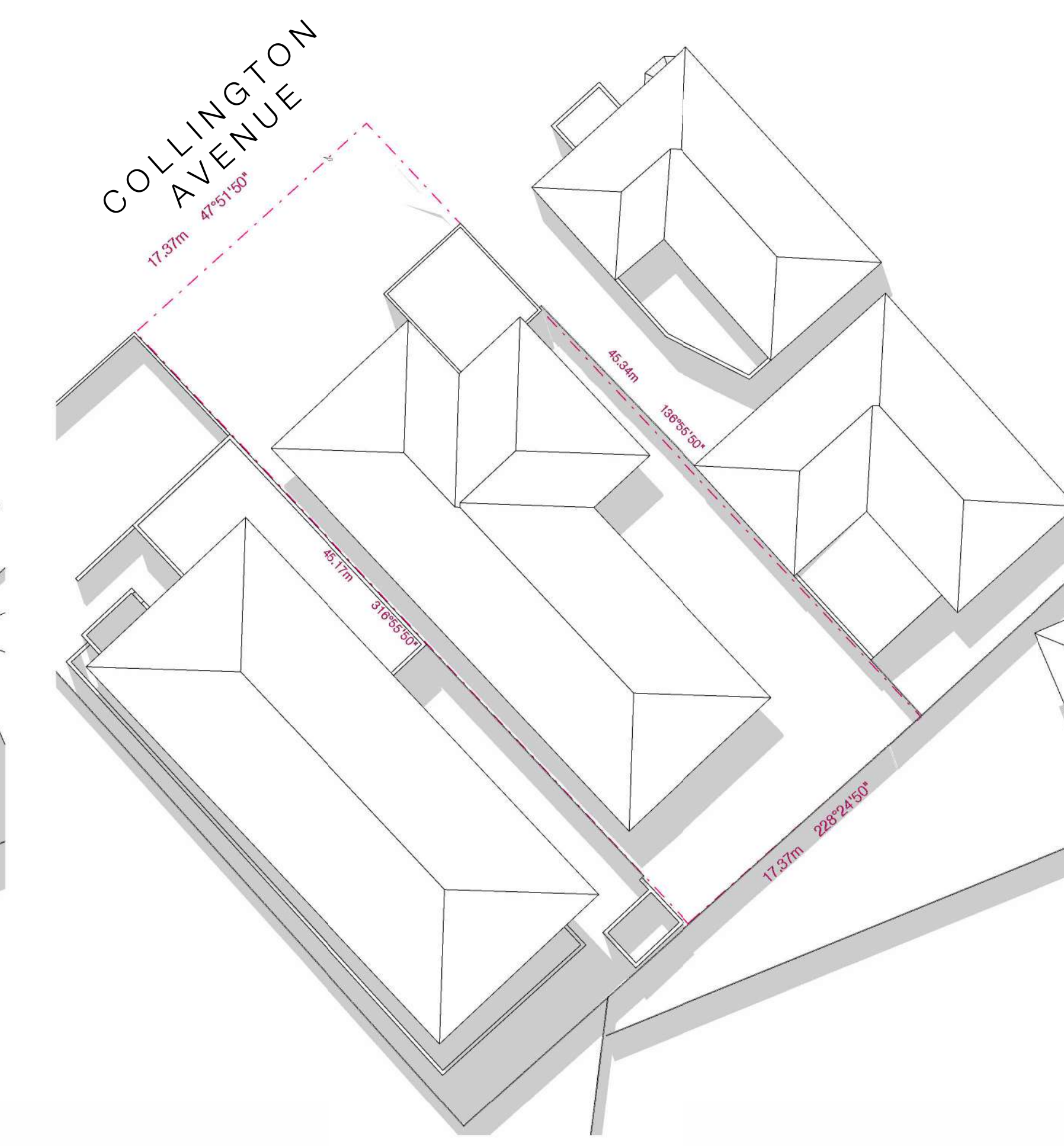
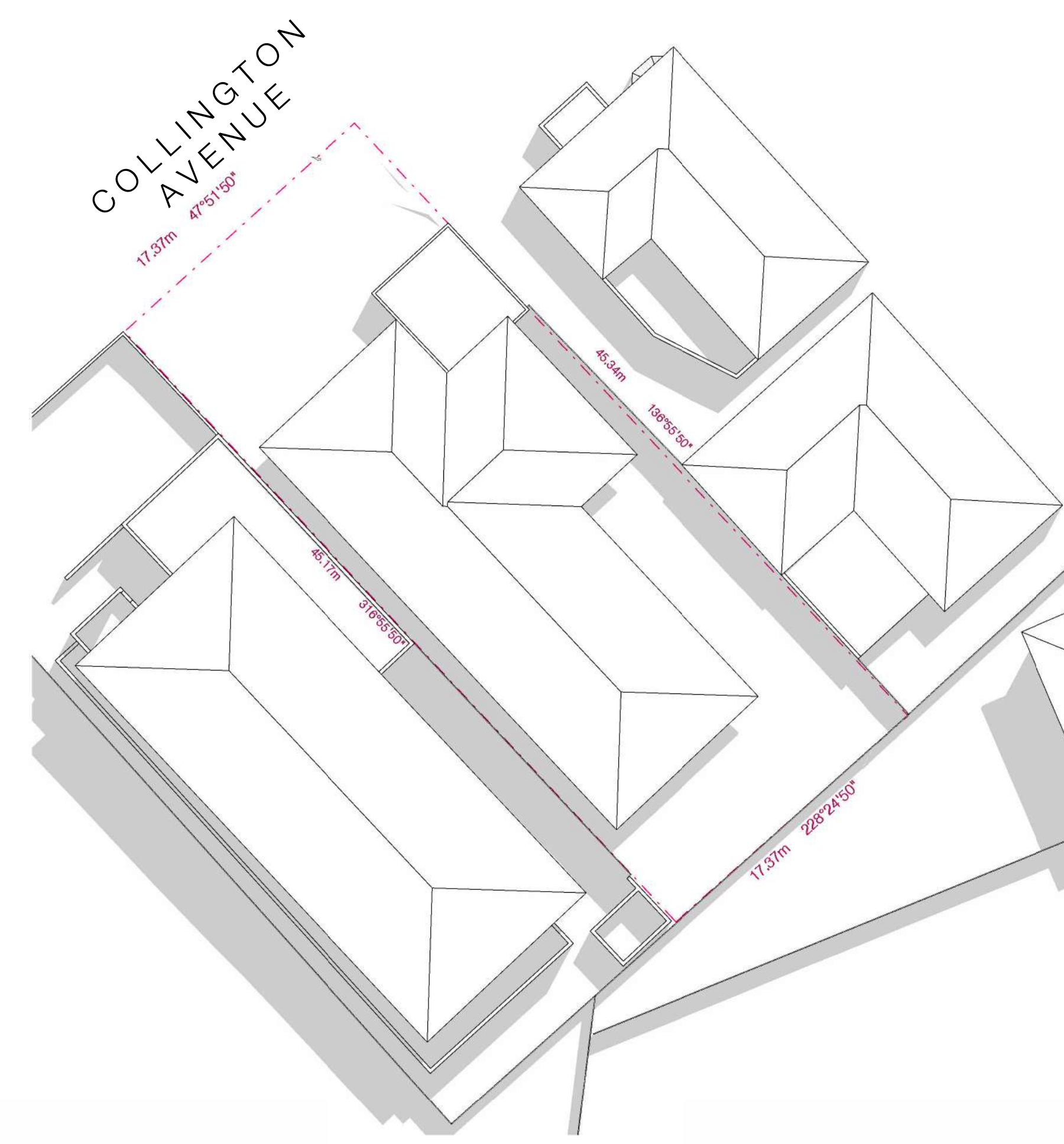
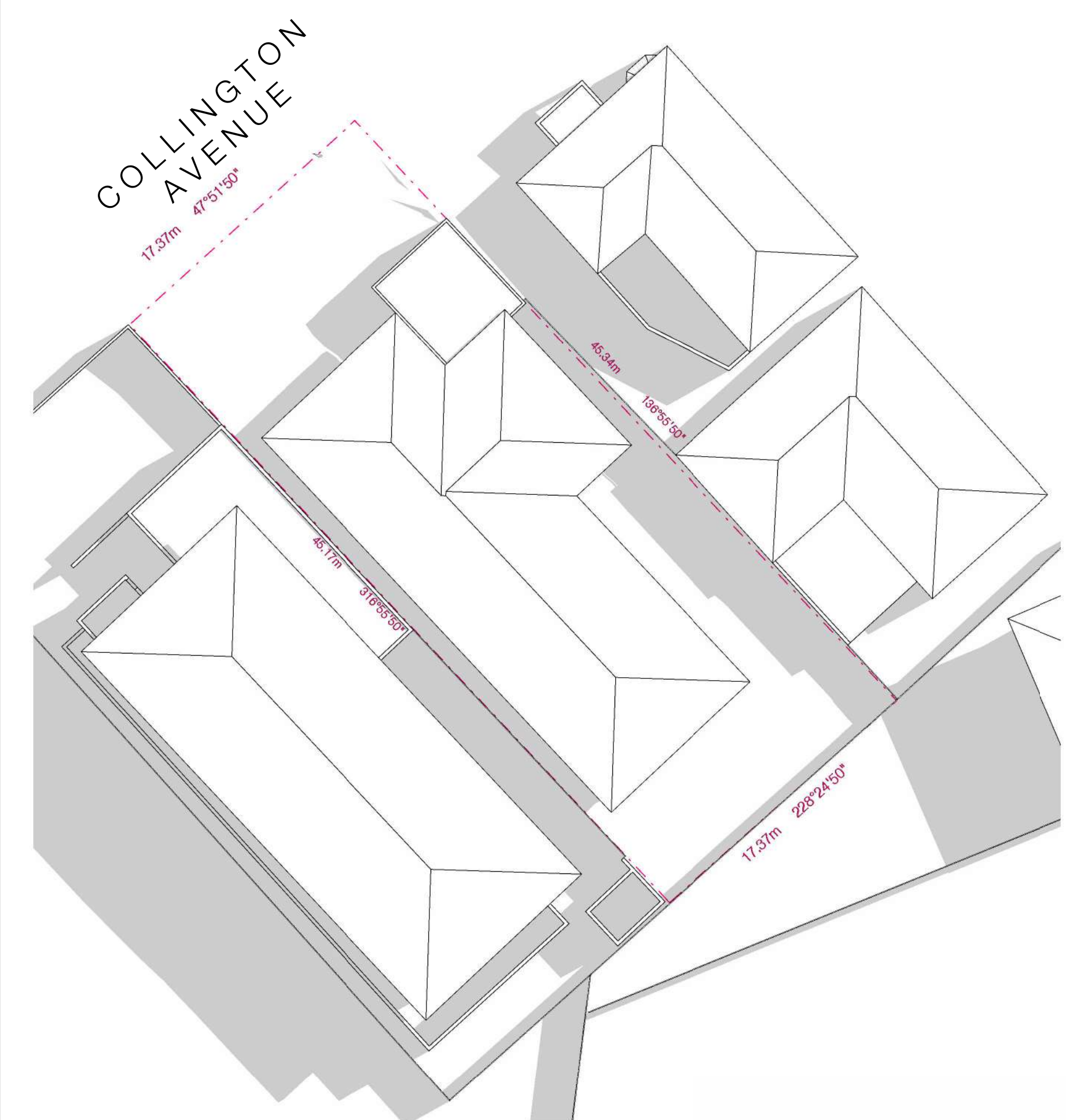

1 Existing Shadow Diagrams - 22 Sept 9am
Scale 1: 250

2 Existing Shadow Diagrams - 22 Sept 11am
Scale 1: 250

3 Existing Shadow Diagrams - 22 Sept 1pm
Scale 1: 250

4 Existing Shadow Diagrams - 22 Sept 3pm
Scale 1: 250

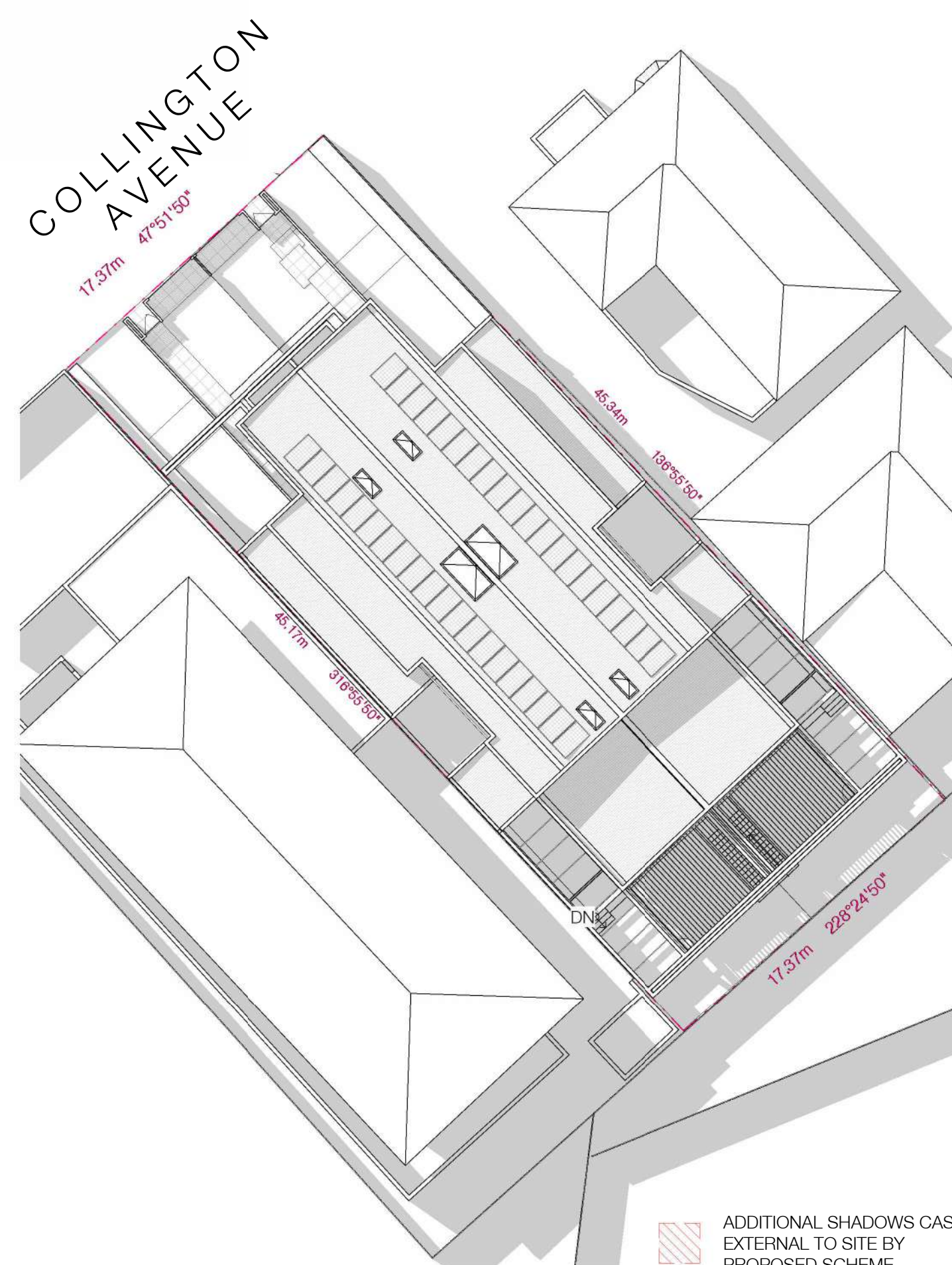
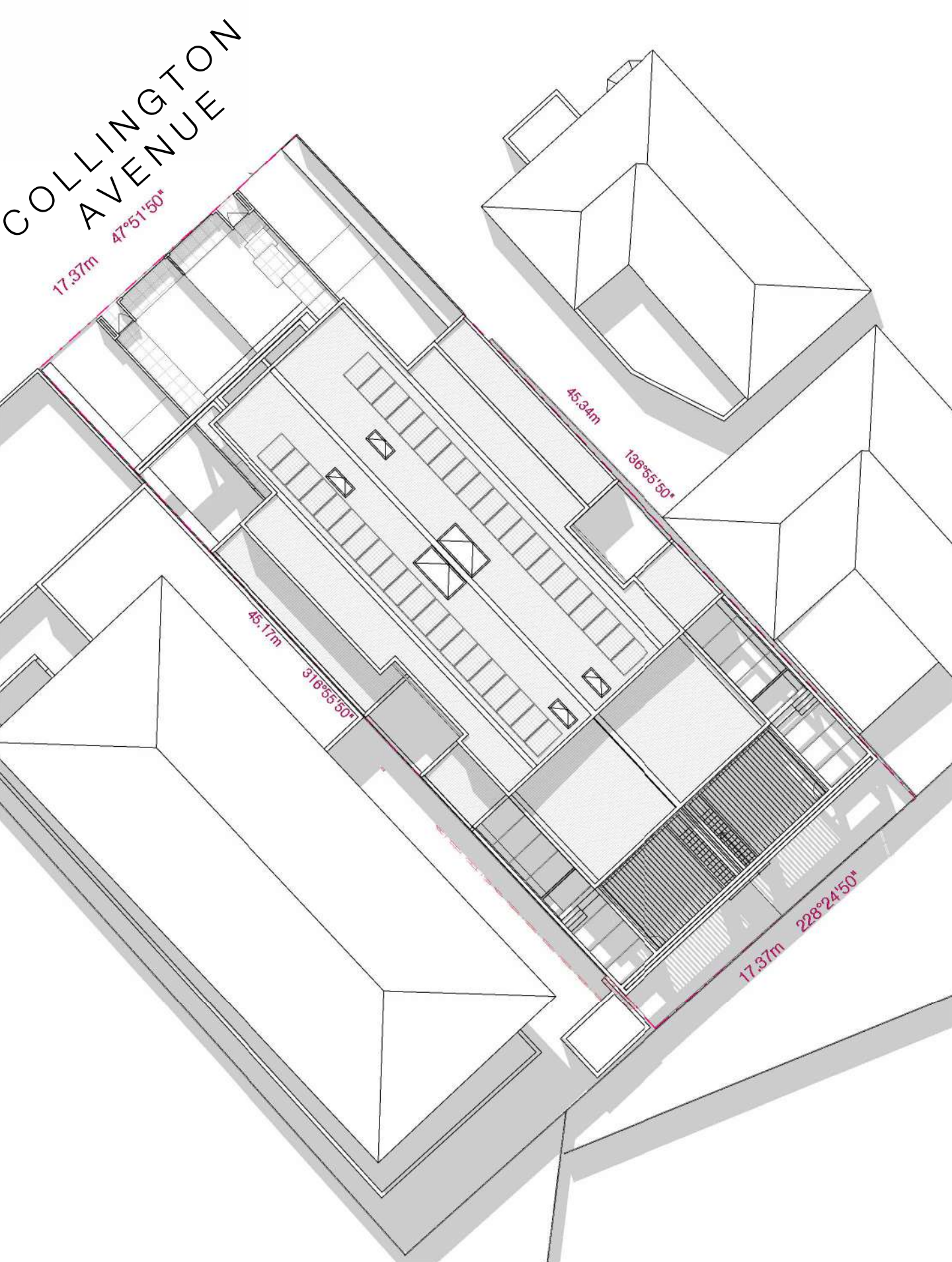
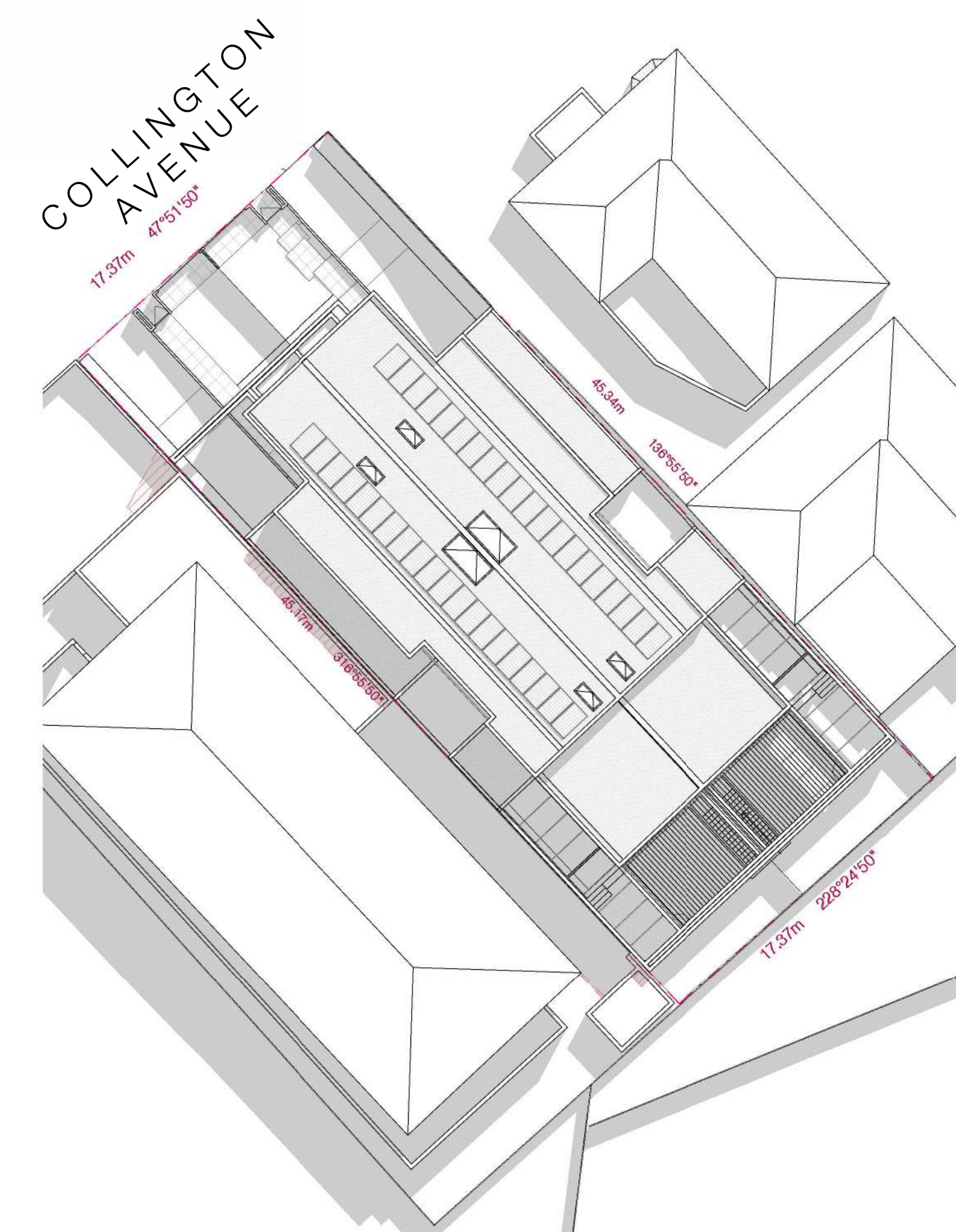
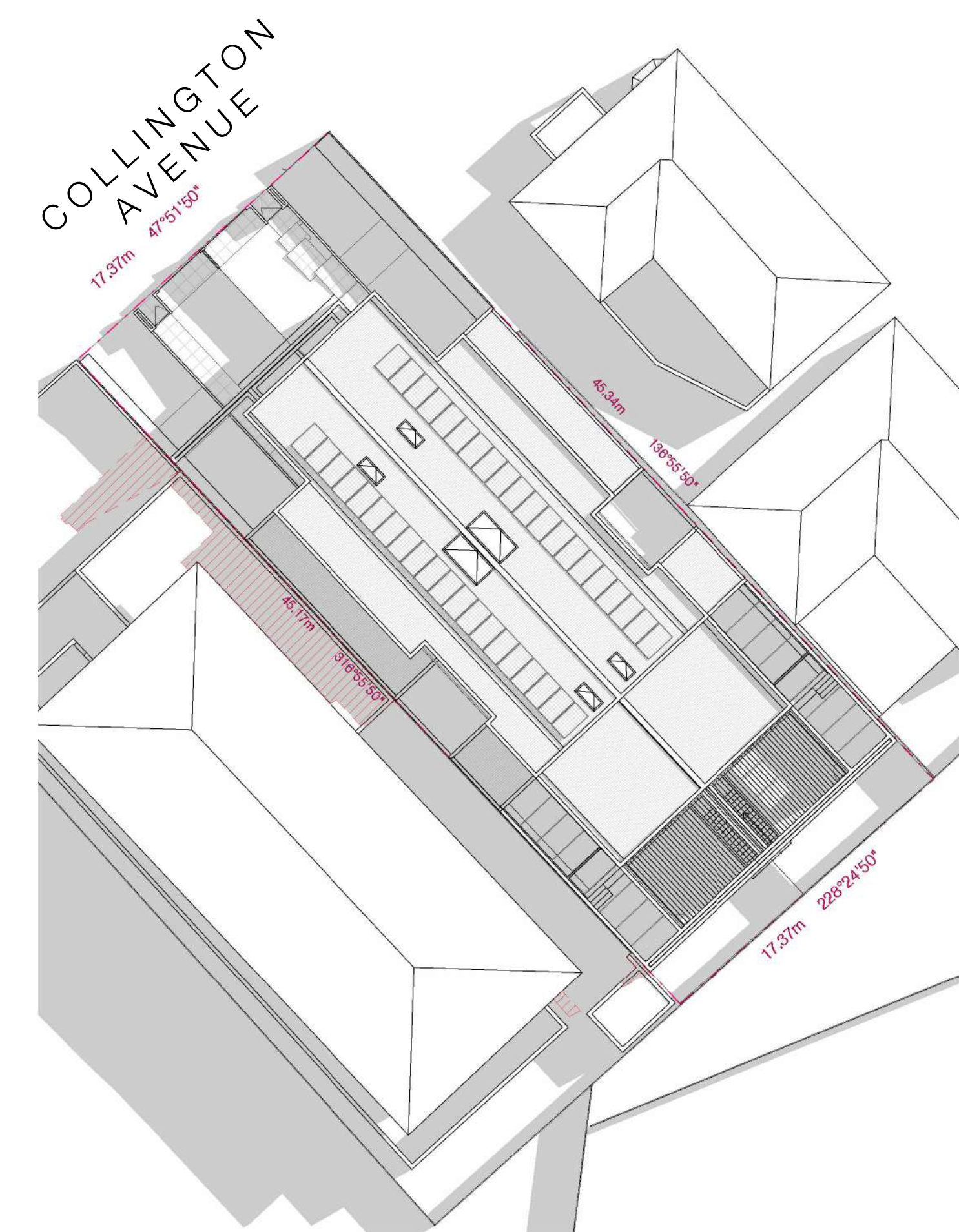

5 Proposed Shadow Diagrams - 22 Sept 9am
Scale 1: 250

6 Proposed Shadow Diagrams - 22 Sept 11am
Scale 1: 250

7 Proposed Shadow Diagrams - 22 Sept 1pm
Scale 1: 250

8 Proposed Shadow Diagrams - 22 Sept 3pm
Scale 1: 250

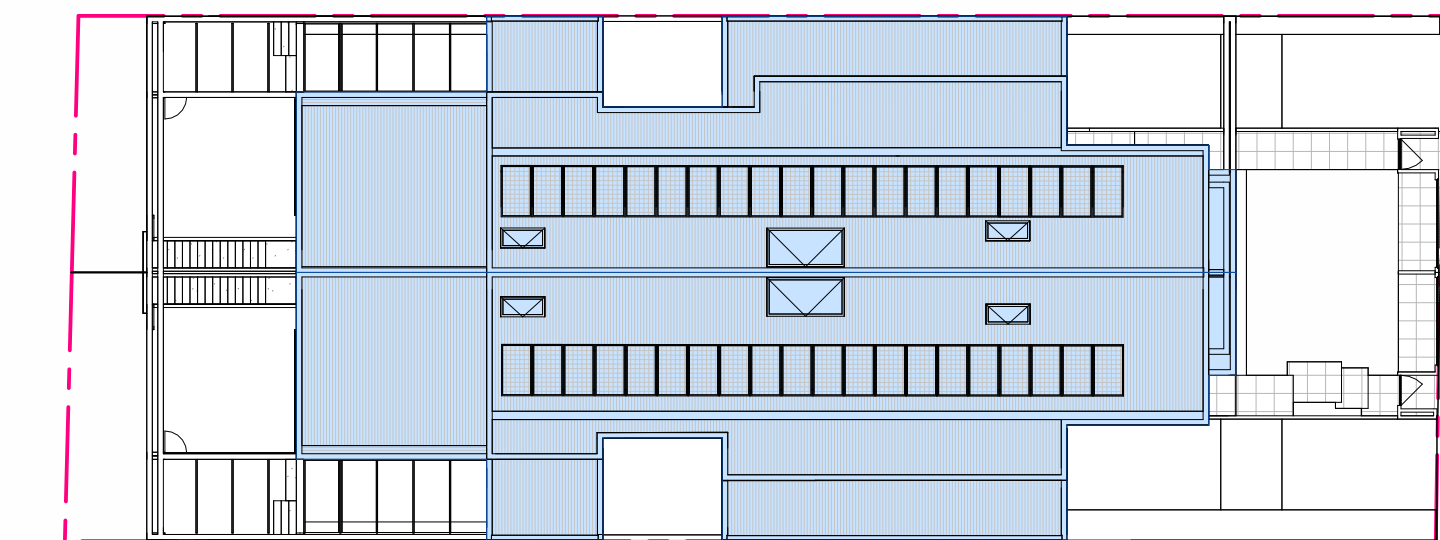

9 Site Coverage
Scale 1: 250

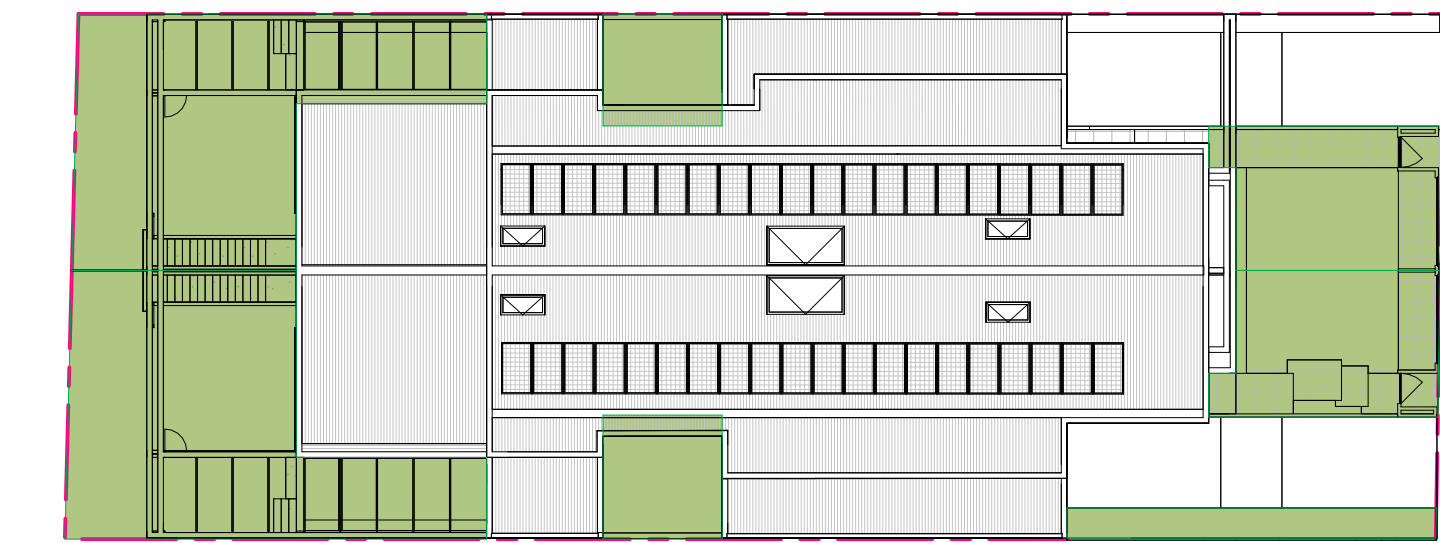

10 Garden Area
Scale 1: 250

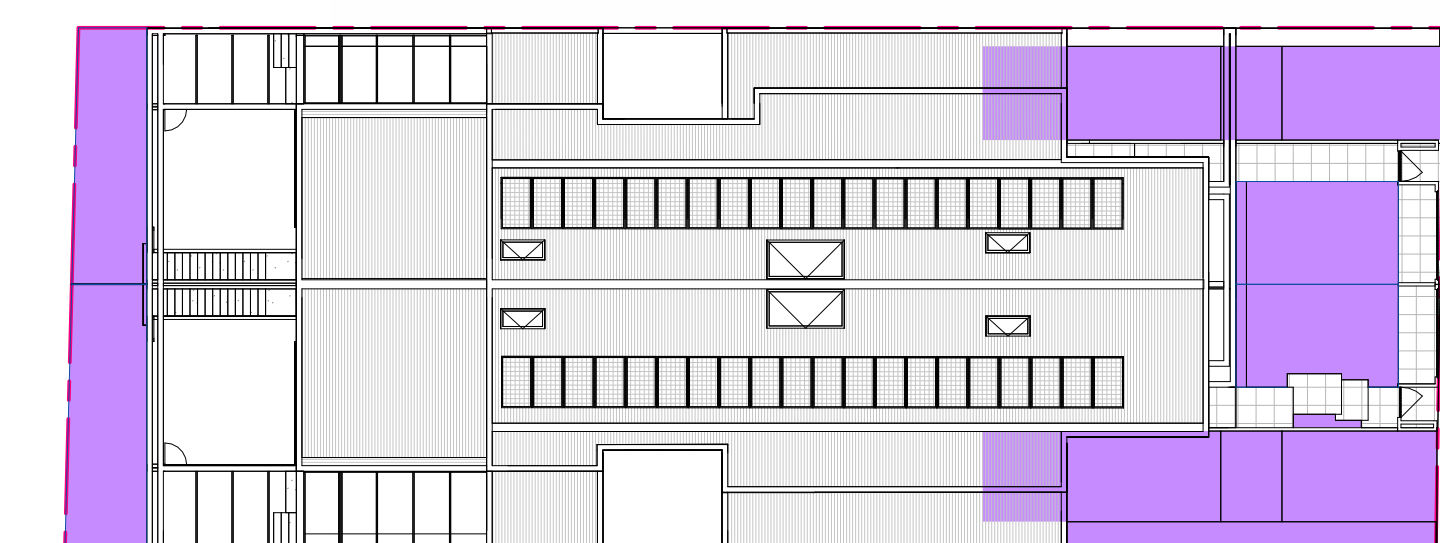

11 Permeability
Scale 1: 250

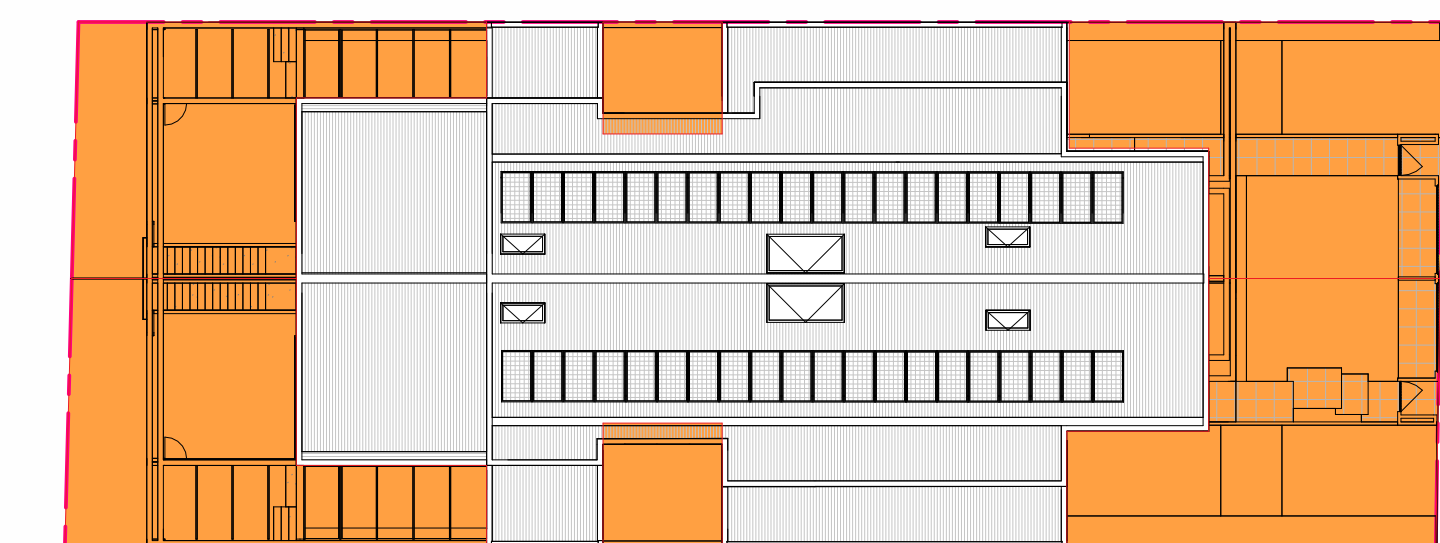

12 Private Open Space
Scale 1: 250

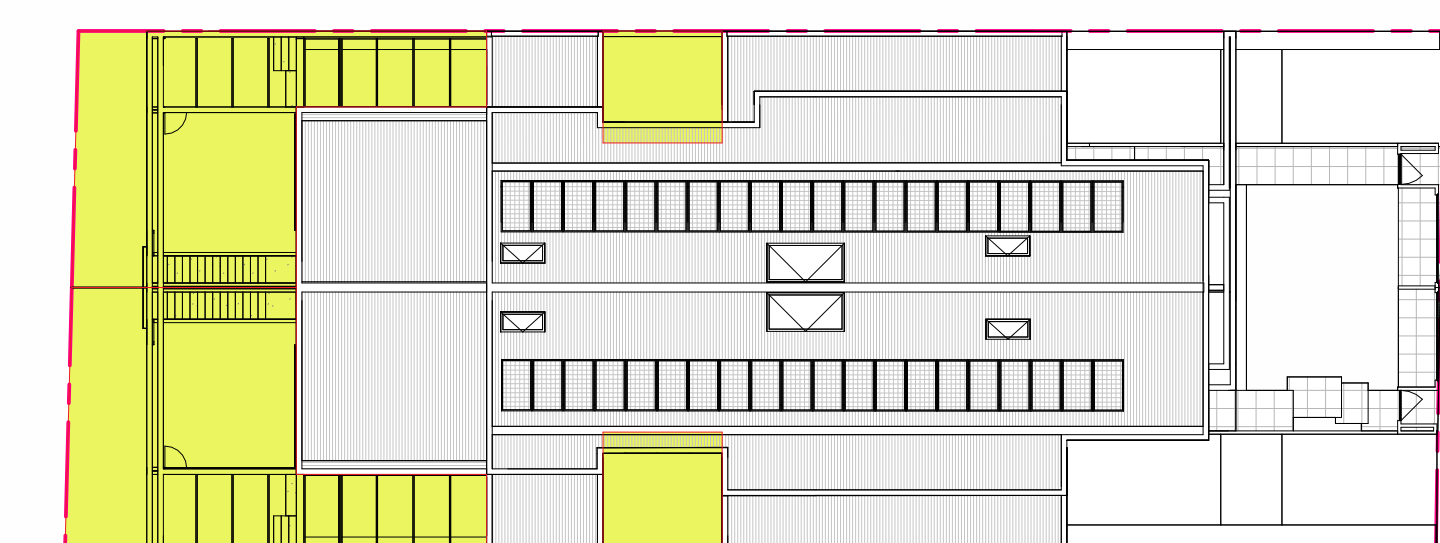

13 Secluded Private Open Space
Scale 1: 250

DEVELOPMENT SUMMARY

Site Area:	785.00m ²
Ex. Site Coverage:	340.33m ² -43.35%
Ex. Permeability:	276.99m ² -35.28%
Ex. POS:	430.45m ²
Ex. SPOS:	277.63m ²
Ex. Garden Area:	429.87m ² -54.76%
UNIT 1	
Site Area:	402.42m ²
Prop. Site Coverage:	222.21m ²
Prop. Permeability:	98.43m ²
Prop. POS:	185.53m ²
Prop. SPOS:	100.17m ²
Prop. Garden Area:	146.27m ² -36.35%
UNIT 2	
Site Area:	383.58m ²
Prop. Site Coverage:	211.09m ²
Prop. Permeability:	85.59m ²
Prop. POS:	177.23m ²
Prop. SPOS:	92.46m ²
Prop. Garden Area:	128.98m ² -33.52%
TOTAL	
Prop. Site Coverage:	433.31m ² 55.20%
Prop. Permeability:	181.77m ² -23.16%
Prop. POS:	357.32m ²
Prop. SPOS:	192.63m ²
Prop. Garden Area:	275.25m ² -35.06%